

Omni-SORB™ IRS Series Standard Fe/Mn Removal Filtration System

Severn Trent Services offers the Omni-SORB™ IRS, a standard pre-engineered product line of filter systems for the combined removal of oxidized iron and manganese from potable ground water sources. Omni SORB IRS systems are also used for the removal of arsenic in the presence of high iron waters. When oxidized iron is filtered out of the water, it also adsorbs and removes arsenic from the water.

The IRS product line features the proprietary Omni-SORB media. IRS standard filter systems are designed in five different filter vessel sizes ranging from 3.5 to 7 foot (1.1 to 2.1 m) diameter. Model numbers include IRS-42, -48, -60, -72 and -84. IRS systems are available in one, two or three adsorber vessel configurations to meet various treatment requirements. Multiple vessel systems are arranged in parallel flow configuration and have a design pressure of 100 psig (7 bar).



Omni-SORB™ IRS Series Features

- Cost-effective treatment solution for iron and manganese removal
- Long media life - 6 to 8 years
- Disinfectant used for oxidation; no chemical addition required
- Standard automatic operation for backwashing events
- Pre-engineered standardized system design
- Simple installation and operation
- Parallel flow configuration
- Simultaneous removal of arsenic from high iron waters

Omni-SORB™ IRS Series Benefits

- Lower water losses - <50% than greensand systems
- Reduces operational and maintenance expenses
- Ensures removal of contaminants
- No need to use permanganate for oxidation
- Pre-engineered systems that are cost effective and with faster delivery



Severn Trent Services
5415 W. Sligh Avenue, Suite 102
Tampa, FL 33634
Tel +1 813 886 9331
Toll-free +1 800 364 3931
Fax +1 813 886 0651
info@severntrentservices.com

A typical IRS system, illustrated below, consists of two filters configured for parallel flow. This arrangement provides enough well water flow to effectively backwash each adsorber when needed and without the need for a supplemental water supply. Other configurations using one or three adsorbers are available to meet specific site requirements and constraints.

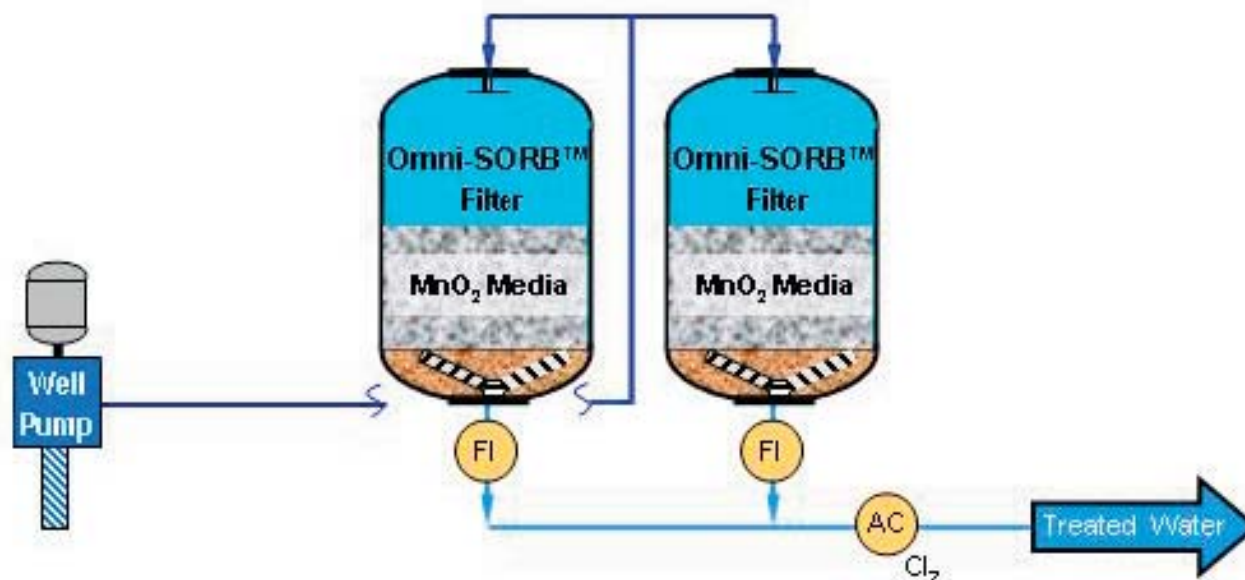

Omni-SORB™ IRS Series Process Description

Omni-SORB is an oxidation precipitation process that converts both iron and manganese to their insoluble forms for filtration onto a catalytic manganese dioxide impregnated media. The filters receive water directly from the well under pressure and after chlorination; repumping is not necessary. As the media filters out iron and manganese oxide solids, the pressure drop across the beds increases. When it reaches a setpoint of about 10 psi (0.7 bar), the filters are backwashed one at a time to remove the solids. They are then returned to filtration service. Either well water or treated water under pressure can be used for backwashing. Omni-SORB media requires only 15 gpm/ft² (36 m/hr) to backwash compared to 22 gpm/ft² (54 m/hr) for other manganese oxide media.

Arsenic present in the water is also removed if the water's iron level is high enough via oxidation and adsorption onto precipitated iron oxide. The minimum iron/arsenic concentration ratio for effective arsenic removal is 25. If there is not enough natural iron in the water, ferric chloride can be dosed into the chlorinated feed water to remove the arsenic. The process is then called coagulation filtration.

Omni-SORB IRS systems are delivered as piped vessels to promote easy installation and commissioning. IRS systems require field interconnecting piping and installation of flowmeters. Then hydrostatic testing is completed and gravel underbedding and media are installed before the system can be fully commissioned.

Omni-SORB IRS systems are operated automatically via PLC controls. Flow meters measure and totalize the treated water flow from the system, pressure gauges monitor the pressure build up, and a treated water analyzer measures free chlorine to ensure there is an adequate residual. Each filter has 5 butterfly process valves, sampling points and manway access for media fill and removal. Media is typically loaded by gravity from supersacks, and spent media is removed by vacuum. The Omni-SORB media has a life of 6–8 years.

Omni-SORB™ IRS Series Options

The Omni-SORB IRS systems are made available with options that help to further optimize operating conditions and integration into the overall water treatment system. Options include:

- pH Adjustment: A pH reduction system using either carbon dioxide or hydrochloric acid can supplement treatment of high pH waters to optimize arsenic removal in coagulation filtration applications.
- NaOCl Dosing: A disinfectant dosing system using sodium hypochlorite can be included.
- FeCl₃ Dosing for arsenic coagulation/filtration: A ferric chloride coagulant dosing system can be included for multi contaminant removal from challenged waters.
- Zero Wastewater Discharge: A backwash decant/reclaim tank and pump can be utilized for those systems without any sewer or other disposal options.
- Distribution Water for Backwash: Treated, clean water from the effluent header can be used for backwashing if required.
- Firm Capacity Requirements: An extra filter can be included in the system to meet firm capacity ("N+1 Redundancy) requirements.

IRS-42 Standard Adsorption System 85 - 255 gpm (19 – 57 m³/hr) Treatment Capacity

Severn Trent Services offers the Omni-SORB IRS-42, a standard filter system available in one, two or three adsorber vessel configurations to meet flow rate requirements of 85, 170 and 255 gpm (19, 38 and 57 m³/hr). Systems feature 3.5 foot diameter (1.1 m) vertical pressure vessels with a capacity of up to 85 gpm (19 m³/hr) each. Multiple vessel systems are arranged in parallel flow configuration.

Omni-SORB™ IRS-42 Model Offering

Model Number	IRS-42S	IRS-42D	IRS-42T
Number of Vessels	1	2	3
Flow Capacity	85 gpm	170 gpm	255 gpm
	19 m ³ /hr	38 m ³ /hr	57 m ³ /hr
Media Volume	32 ft ³	64 ft ³	96 ft ³
	0.9 m ³	1.8 m ³	2.7 m ³
Backwash Rate (Max)	145 gpm	145 gpm	145 gpm
	33 m ³ /hr	33 m ³ /hr	33 m ³ /hr
Vessel Diameter	3.5 ft	3.5 ft	3.5 ft
	1.1 m	1.1 m	1.1 m
System Footprint (Length x Width)	5 ft x 5 ft	10 ft x 5 ft	15 ft x 5 ft
	1.5 m x 1.5 m	3.0 m x 1.5 m	4.5 m x 1.5 m

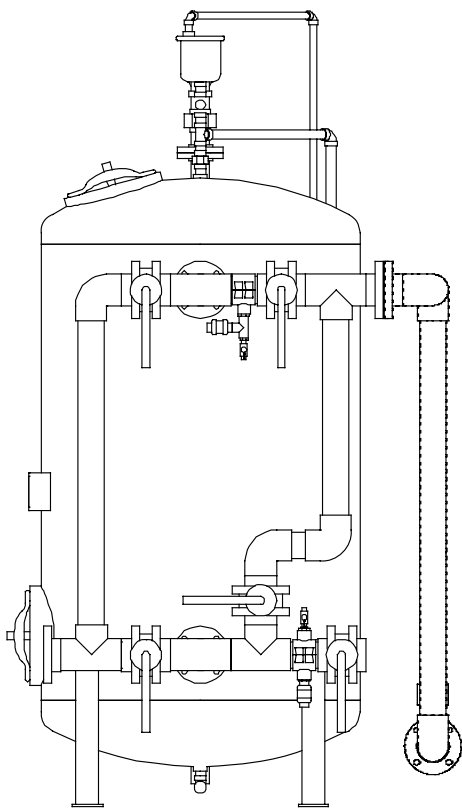

Front View

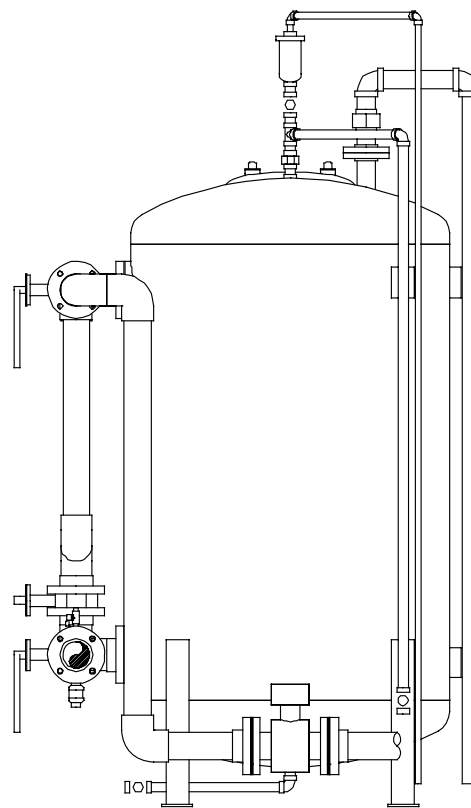

Side View

IRS-48 Standard Adsorption System 110 - 330 gpm (25 – 75 m³/hr) Treatment Capacity

Severn Trent Services offers the Omni-SORB IRS-48, a standard filter system available in one, two or three adsorber vessel configurations to meet flow rate requirements of 110, 220 and 330 gpm (25, 50 and 75 m³/hr). Systems feature 4 foot diameter (1.2 m) vertical pressure vessels with a capacity of up to 110 gpm (25 m³/hr) each. Multiple vessel systems are arranged in parallel flow configuration.

Omni-SORB™ IRS-48 Model Offering

Model Number	IRS-48S	IRS-48D	IRS-48T
Number of Vessels	1	2	3
Flow Capacity	110 gpm	220 gpm	330 gpm
	25 m ³ /hr	50 m ³ /hr	75 m ³ /hr
Media Volume	63 ft ³	125 ft ³	188 ft ³
	1.8 m ³	3.5 m ³	5.3 m ³
Backwash Rate (Max)	190 gpm	190 gpm	190 gpm
	43 m ³ /hr	43 m ³ /hr	43 m ³ /hr
Vessel Diameter	4.0 ft	4.0 ft	4.0 ft
	1.2 m	1.2 m	1.2 m
System Footprint (Length x Width)	6 ft x 6 ft	12 ft x 6 ft	18 ft x 6 ft
	1.8 m x 1.8 m	3.6 m x 1.8 m	5.5 m x 1.8 m

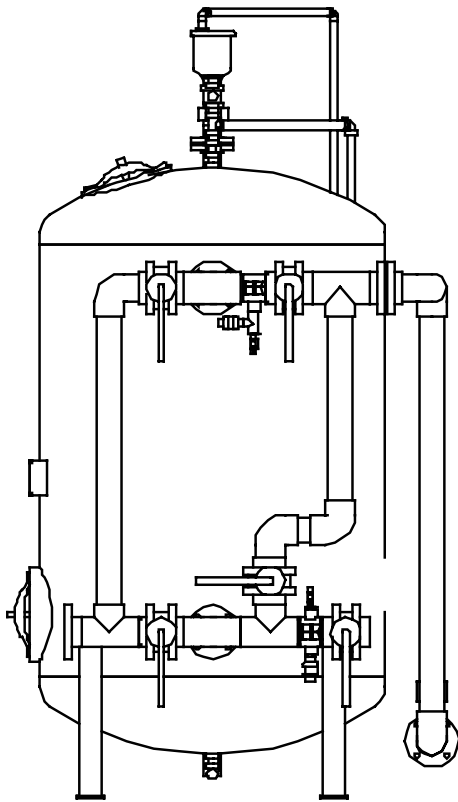

Front View

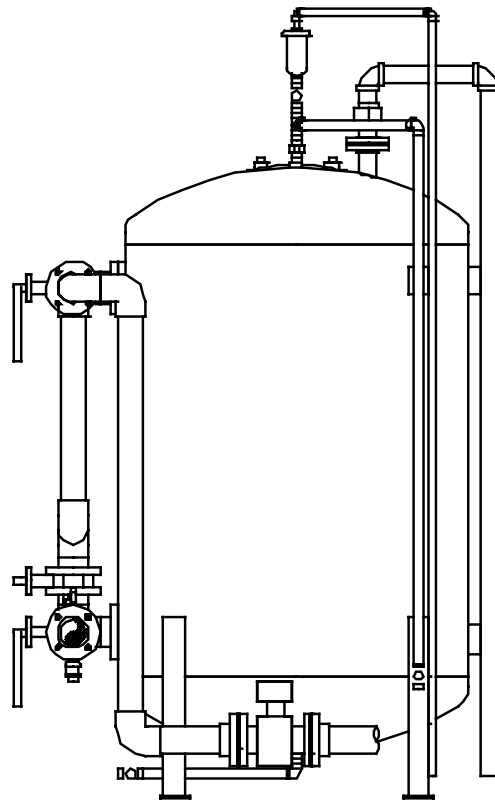

Side View

IRS-60 Standard Adsorption System 175 - 525 gpm (40 - 120 m³/hr) Treatment Capacity

Severn Trent Services offers the Omni-SORB IRS-60, a standard filter system available in one, two or three adsorber vessel configurations to meet flow rate requirements of 175, 350 and 525 gpm (40, 80 and 120 m³/hr). Systems feature 5 foot diameter (1.5 m) vertical pressure vessels with a capacity of up to 175 gpm (40 m³/hr) each. Multiple vessel systems are arranged in parallel flow configuration.

Omni-SORB™ IRS-60 Model Offering

Model Number	IRS-60S	IRS-60D	IRS-60T
Number of Vessels	1	2	3
Flow Capacity	175 gpm	350 gpm	525 gpm
	40 m ³ /hr	80 m ³ /hr	120 m ³ /hr
Media Volume	63 ft ³	125 ft ³	188 ft ³
	1.8 m ³	3.5 m ³	5.3 m ³
Backwash Rate (Max)	300 gpm	300 gpm	300 gpm
	68 m ³ /hr	68 m ³ /hr	68 m ³ /hr
Vessel Diameter	5.0 ft	5.0 ft	5.0 ft
	1.5 m	1.5 m	1.5 m
System Footprint (Length x Width)	7 ft x 7 ft	14 ft x 7 ft	21 ft x 7 ft
	2.1 m x 2.1 m	4.3 m x 2.1 m	6.4 m x 2.1 m

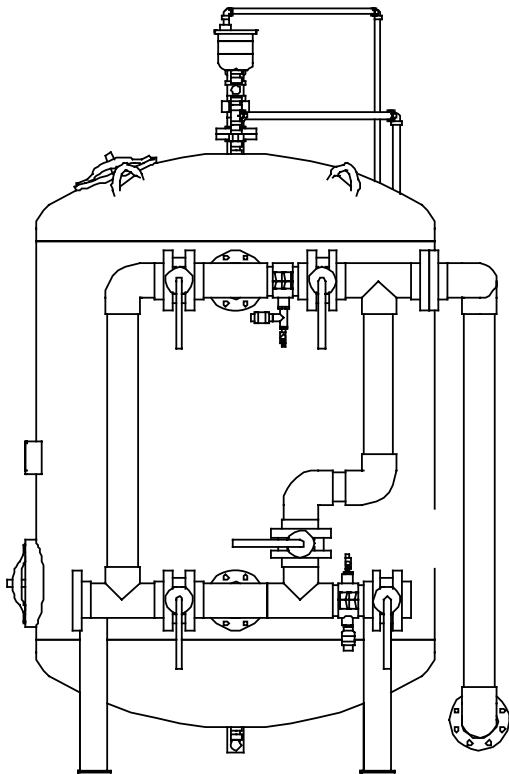

Front View

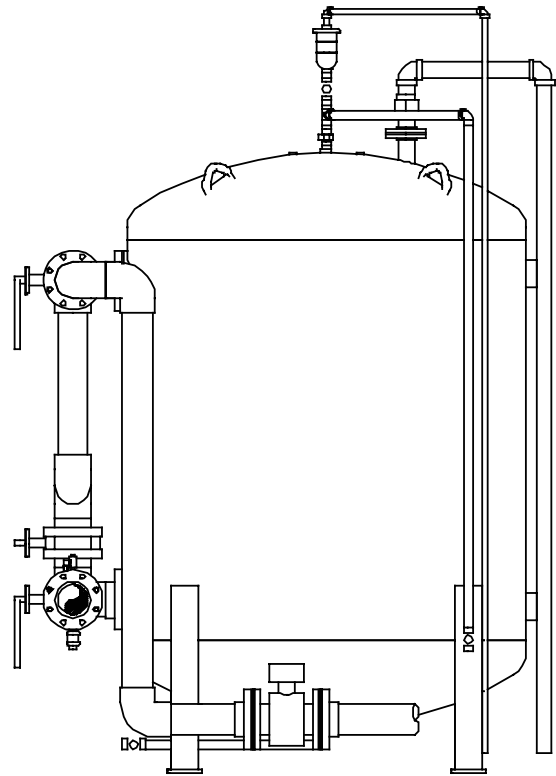

Side View

IRS-72 Standard Adsorption System 250 - 750 gpm (57 - 170 m³/hr) Treatment Capacity

Severn Trent Services offers the Omni-SORB IRS-72, a standard filter system available in one, two or three adsorber vessel configurations to meet flow rate requirements of 250, 500 and 750 gpm (57, 114 and 170 m³/hr). Systems feature 6 foot diameter (1.8 m) vertical pressure vessels with a capacity of up to 175 gpm (40 m³/hr) each. Multiple vessel systems are arranged in parallel flow configuration.

Omni-SORB™ IRS-72 Model Offering

Model Number	IRS-72S	IRS-72D	IRS-72T
Number of Vessels	1	2	3
Flow Capacity	250 gpm	500 gpm	750 gpm
	57 m ³ /hr	114 m ³ /hr	170 m ³ /hr
Media Volume	100 ft ³	200 ft ³	300 ft ³
	2.8 m ³	5.6 m ³	8.4 m ³
Backwash Rate (Max)	425 gpm	425 gpm	425 gpm
	95 m ³ /hr	95 m ³ /hr	95 m ³ /hr
Vessel Diameter	6.0 ft	6.0 ft	6.0 ft
	1.8 m	1.8 m	1.8 m
System Footprint (Length x Width)	8 ft x 8 ft	16 ft x 8 ft	24 ft x 8 ft
	2.4 m x 2.4 m	4.8 m x 2.4 m	7.2 m x 2.4 m

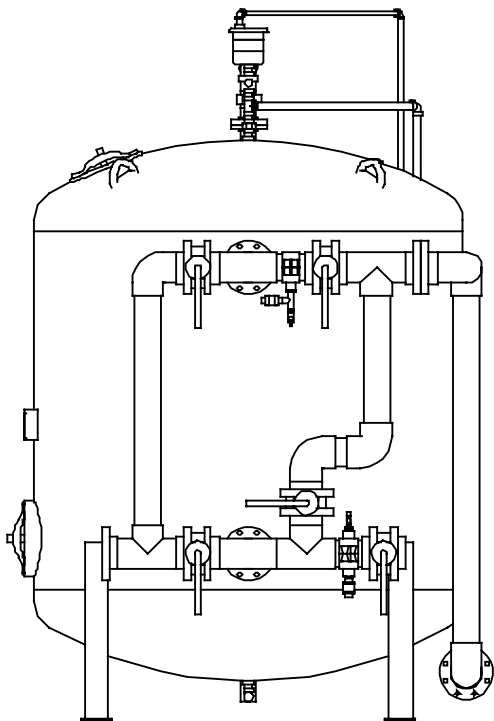

Front View

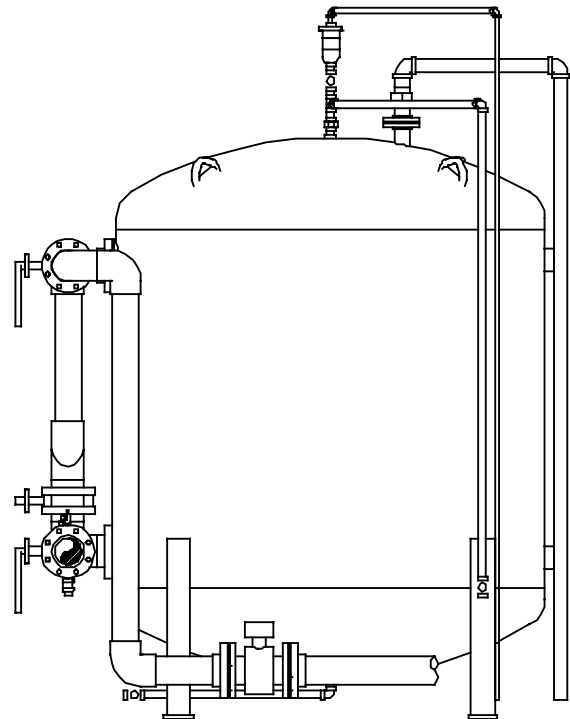

Side View

IRS-84 Standard Adsorption System 350 – 1,050 gpm (80 – 240 m³/hr) Treatment Capacity

Severn Trent Services offers the Omni-SORB IRS-84, a standard filter system available in one, two or three adsorber vessel configurations to meet flow rate requirements of 350, 700 and 1,050 gpm (80, 160 and 240 m³/hr). Systems feature 7 foot diameter (2.1 m) vertical pressure vessels with a capacity of up to 350 gpm (80 m³/hr) each. Multiple vessel systems are arranged in parallel flow configuration.

Omni-SORB™ IRS-84 Model Offering

Model Number	IRS-84S	IRS-84D	IRS-84T
Number of Vessels	1	2	3
Flow Capacity	350 gpm	700 gpm	1,050 gpm
	80 m ³ /hr	160 m ³ /hr	240 m ³ /hr
Media Volume	125 ft ³	250 ft ³	375 ft ³
	3.5 m ³	7.0 m ³	10.5 m ³
Backwash Rate (Max)	575 gpm	575 gpm	575 gpm
	130 m ³ /hr	130 m ³ /hr	130 m ³ /hr
Vessel Diameter	7.0 ft	7.0 ft	7.0 ft
	2.1 m	2.1 m	2.1 m
System Footprint (Length x Width)	9 ft x 9 ft	18 ft x 9 ft	27 ft x 9 ft
	2.7 m x 2.7 m	5.5 m x 2.7 m	8.2 m x 2.7 m

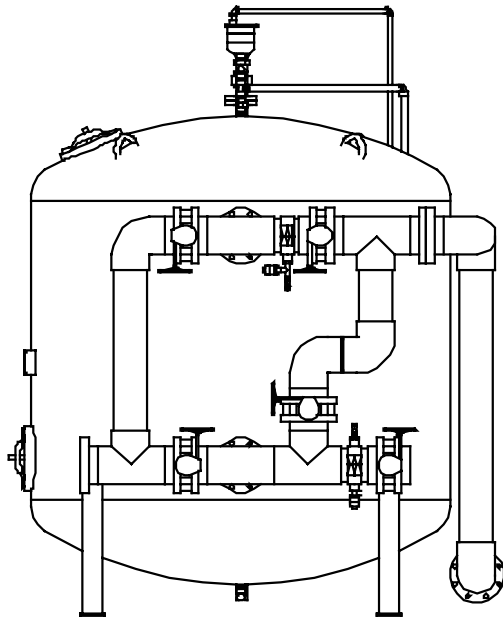

Front View

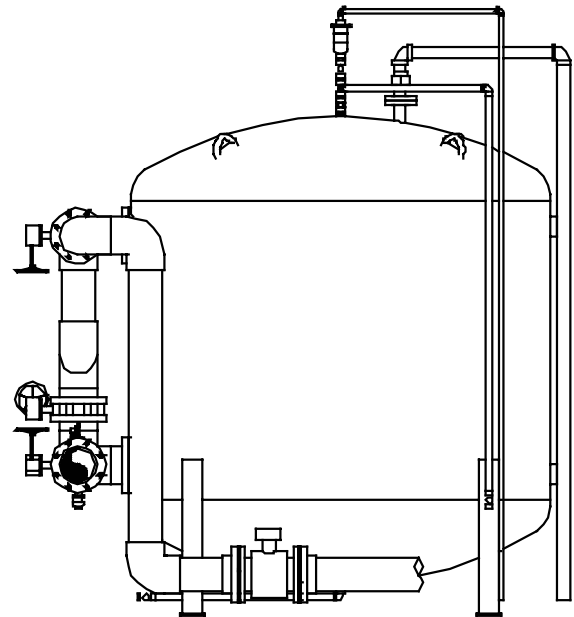

Side View

565.0405.0 JUN/10