

# Capital Controls

## Model T70GD4000

### Chlorine Dioxide Generators

The Model T70GD4000 chlorine dioxide generator is designed to produce and consistently maintain a product yield greater than 95%, which makes it ideal for drinking water treatment. It is a two-chemical system, utilizing diluted concentrations of hydrochloric acid and sodium chlorite in the production of chlorine dioxide. No chlorine gas is required. A proven design, durable construction and the use of the best available corrosion-resistant materials assure efficient gas production, precise solution feeding, low maintenance and dependable operation for the life of the equipment.

The Model T70GD4000 chlorine dioxide generator is an all-liquid system. Research has shown a market trend towards chlorine dioxide generators that do not require chlorine gas for the production of chlorine dioxide. This system is designed for use with 8.5% hydrochloric acid and 7.5% sodium chlorite, fed at a 1:1 ratio. The generator design combines vacuum technology with dosing pump flexibility to generate chlorine dioxide from low hazard (diluted) sodium chlorite and hydrochloric acid.

The Model T70GD4000 chlorine dioxide generator is available with either manual or automatic control. Both methods of control are performed using Biochem, a microprocessor based control system. The Biochem includes a keypad for manual control. In the case of automatic control, the Biochem accepts a 4-20 mAdc input signal. The Biochem provides alarm contacts for pump failure, low vacuum condition and low reagent flow.



#### DESIGN FEATURES

- ◆ **High Yield:** Generator has been designed to produce and consistently maintain a product yield greater than 95%.
- ◆ **All Liquid System:** Diluted hydrochloric acid and sodium chlorite are the reagents used to generate chlorine dioxide. No chlorine gas is required.
- ◆ **Pressure/vacuum process:** The generator design combines vacuum technology with dosing pump accuracy to generate chlorine dioxide from low hazard (diluted) sodium chlorite and hydrochloric acid.
- ◆ **Manual or Automatic Control Options**
- ◆ **Safe Operation:** With system shut-down and alarm options.
- ◆ **Minimum maintenance:** Corrosion-resistant materials; All periodic maintenance items are easily replaceable.



## ENGINEERING SPECIFICATIONS

### Capacities:

Standard chlorine dioxide generator units are available in the following maximum capacities: 1, 3, 5, 13, 26, 53 PPD (25, 50, 100, 250, 500, 1000 g/h) of chlorine dioxide gas.

### Flowmeter Rangeability:

10 to 1, flowmeter indication and control limits.

### Control Options:

The generator can be controlled either manually or automatically using the Biochem, a microprocessor based control system. The Biochem includes a keypad for manual control. In the case of automatic control, the Biochem accepts a 4-20 mAdc input signal. The Biochem provides alarm contacts for pump failure, low vacuum condition and low reagent flow.

### Safety Features:

The generator is equipped with a check valve on the ejector motive water line and a check valve on the chlorine dioxide solution line. In the event of vacuum loss for any reason, the Biochem controller will shut-down the generator, including the dosing pumps. The pumps will not restart until a vacuum switch provides a signal that a vacuum condition exists. A relief valve protects the pumps from over pressure. Optional reagent tank level sensors are also available. Alarm contacts are provided for pump failure, low vacuum condition and low reagent flow. A contact is also available for remote generator shut-down in the event of chlorine dioxide presence in the air.

### Connections:

Ejector water inlet: 1/2" NPT  
Chlorine dioxide solution: 1/2" NPT  
Reagents inlet: 1/2" NPT  
Drain: 1/2" NPT

### Electrical Requirements:

115 VAC, 60 Hz (230 VAC, 50 Hz)  
50 VA Max.

### Enclosure:

NEMA 4X (IP 65) for Biochem and dosing pumps

### Biochem:

Digital LCD, 16+16 character display

### Input/Output Signals (Auto. Unit):

- (1) 4-20 mAdc input for flow control
- (1) 4-20 mAdc output
- (8) digital inputs
- (8) digital outputs: (5) outputs 5A, 120V, 60Hz (220V, 50 Hz) and (3) outputs for reagent pump control

### Temperature Limits:

41 to 113°F (5 to 45°C), optimum conditions are achieved at 68°F (20°C)

### Reagents:

Diluted concentrations, fed at a 1:1 ratio:  
8.5% Hydrochloric Acid (Hydrofluoric Acid Free)  
7.5% Sodium Chlorite

Produces a 1.8 g/l chlorine dioxide solution.

### Dimensions:

64.25 x 34.25 x 21.6 inches (1630 x 870 x 550 mm)

### Shipping Weight:

119 to 128 lbs (54 to 58 kg)

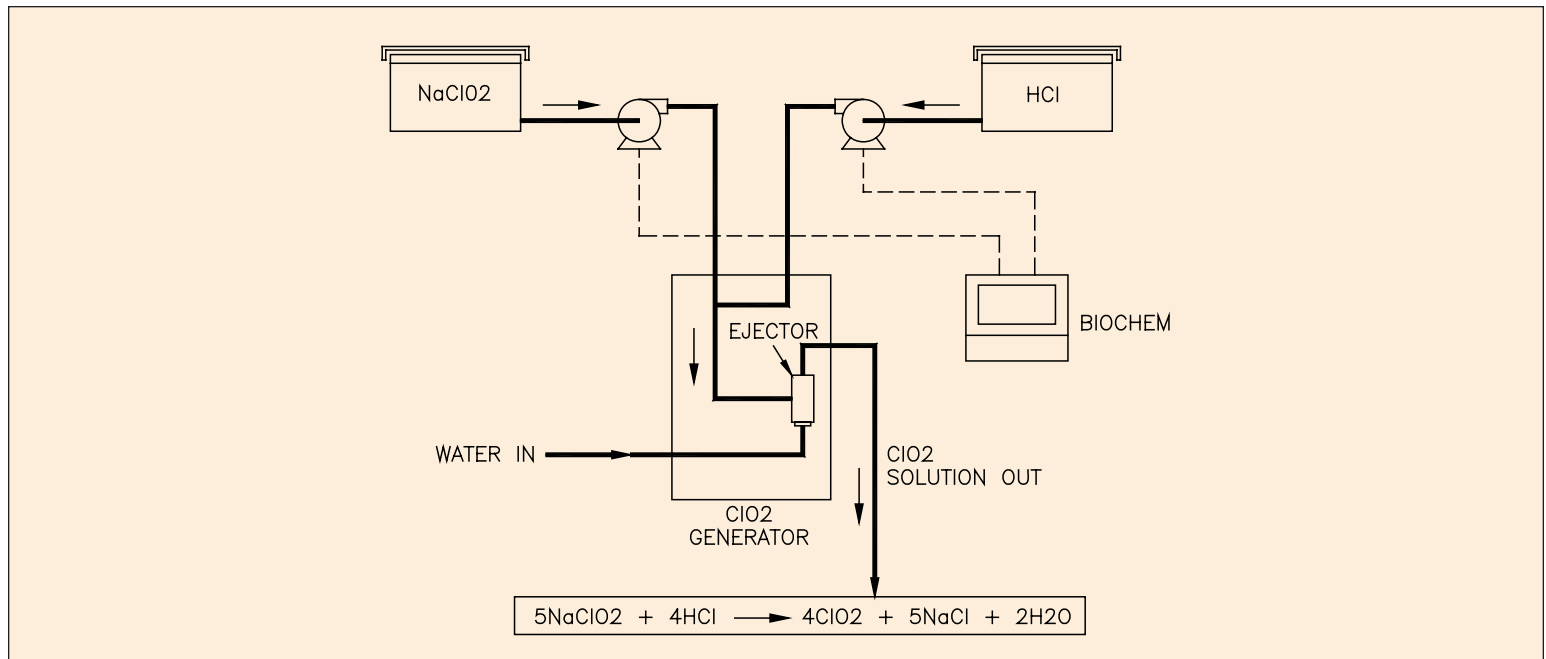

Figure 1 - Flow Diagram

### Standard Unit Features:

- Dosing pumps: electromagnetic, piston-type
- Sight glass for chlorine dioxide solution, for visual verification of product quality
- Vacuum gauge, psi/kPa
- Low vacuum alarm contact, 5A, 120V, 60 Hz (220V, 50 Hz)
- Alarm indication with manual reset
- Pressure relief valve, for pump protection
- Ejector water line and solution line check valves

### MATERIALS OF CONSTRUCTION:

Frame: epoxy resin painted steel  
Reaction tower: PVC  
Mounting plates: PVC  
Ejector: PVC  
Mixing chamber: PVC  
Biochem case: ABS, reinforced fiberglass (17%)  
Tubing and connections: Teflon/PVDF

### OPTIONAL ACCESSORIES AVAILABLE:

- Reagent tank level sensors
- Serial link (RS485, RS232 or RS422)

### DESCRIPTION OF OPERATION

The diluted hydrochloric acid and sodium chlorite reagents are metered into the generator reaction chamber, at a 1:1

ratio, using dosing pumps. For manual control systems the reagent flow, or reagent pump flowrate, is controlled via the operator interface keypad on the Biochem controller. For automatically controlled systems, the Biochem controller accepts a 4-20 mAdc input signal and adjusts reagent flow according to chlorine dioxide demand.

The chlorine dioxide gas is drawn out of the reaction chamber under a vacuum produced by the integral ejector where it is mixed with the ejector motive water and applied as a solution. The solution is passed through a sight glass for visual verification of product quality.

The generator is equipped with a check valve on the ejector motive water line and a check valve on the chlorine dioxide solution line. A relief valve is included to protect the pumps from over pressure.

In the event of vacuum loss for any reason, a vacuum switch will send a signal to the Biochem controller. The Biochem controller will shut-down the generator, including the dosing pumps. A low vacuum alarm contact is included. The pumps will not restart until the vacuum switch provides a signal that a vacuum condition exists. The Biochem will also shut-down the generator in the event of a pump failure or loss of reagent flow. The Biochem provides alarm contacts for pump failure, low vacuum condition and low reagent flow.

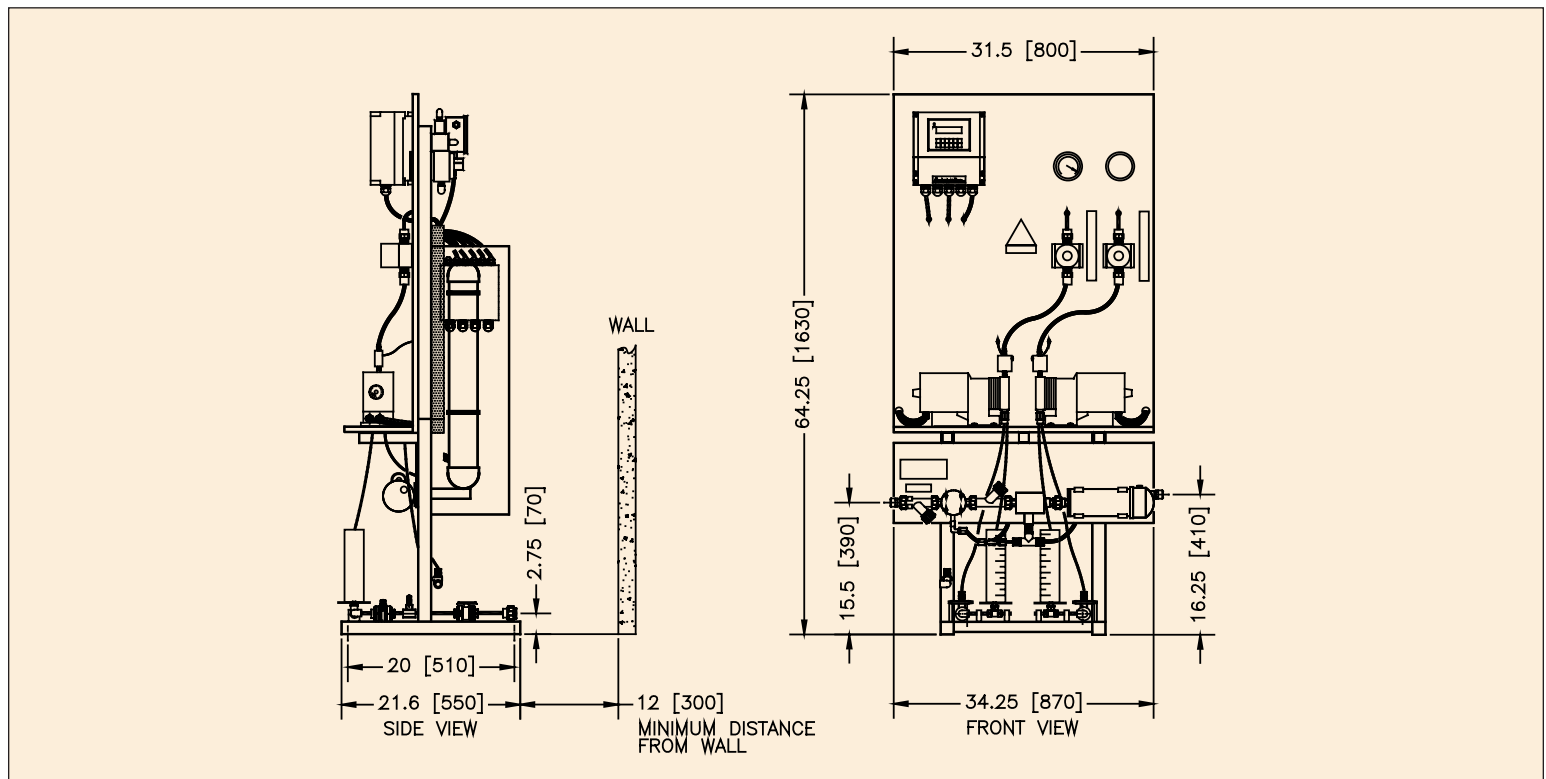

Figure 2 - Dimensions

## EQUIPMENT DESCRIPTION

The chlorine dioxide generation system shall be an all-liquid type with a capacity of \_\_\_\_\_ PPD (g/h) of chlorine dioxide. The unit shall be designed to produce and consistently maintain a product yield greater than 95%.

The system shall be a two-chemical reagent type, utilizing diluted hydrochloric acid and sodium chlorite, fed at a 1:1 ratio, in the production of chlorine dioxide gas. No chlorine gas is required. The reagents are to be metered into the generator by dosing pumps.

The chlorine dioxide gas produced by the generator shall be mixed with the integral ejector motive water and applied as a solution. The generator shall be equipped with a check valve on the ejector motive water line and a check valve on the chlorine dioxide solution line. A relief valve shall be included to protect the dosing pumps from over pressure.

(Manual Systems) Reagent flow into the system, or reagent pump flowrate, shall be manually controlled via the operator interface keypad on the Biochem controller, thereby controlling the rate of chlorine dioxide gas production.

(Automatic Systems) The chlorine dioxide generating system shall be flow paced. Reagent flow into the system shall be controlled by the Biochem controller, that will receive a 4-20 mAdc signal from the process (flowmeter or control source) and adjust the rate of reagent flow accordingly in order to ultimately control the rate of chlorine dioxide production.

The chlorine dioxide generator frame shall be constructed of epoxy resin painted steel. The reaction chamber, mounting plates, ejector and mixing chamber shall be constructed of PVC. The Biochem case shall be constructed of ABS, reinforced fiberglass.

Safety interlocks shall be provided to automatically shut down the system in the event of a loss of vacuum, pump failure or low reagent flow.

### Severn Trent Services

3000 Advance Lane

Colmar, PA 18915

Telephone 215 997 4000

Fax 215 997 4062

[marketing@severntrentservices.com](mailto:marketing@severntrentservices.com)

150.0020.2 02/06