

Capital Controls

Model T70G4000

Chlorine Dioxide Generators

The Model T70G4000 chlorine dioxide generator is designed to produce and consistently maintain a product yield greater than 95%, which makes it ideal for drinking water treatment. It is a two-chemical system, utilizing commercially available concentrations of hydrochloric acid and sodium chlorite in the production of chlorine dioxide. No chlorine gas is required. A proven design, durable construction and the use of the best available corrosion-resistant materials assure efficient gas production, precise solution feeding, low maintenance and dependable operation for the life of the equipment.

The Model T70G4000 chlorine dioxide generator is an all-liquid system. Research has shown a market trend towards chlorine dioxide generators that do not require chlorine gas for the production of chlorine dioxide. This system is designed for use with 32% hydrochloric acid and 25% sodium chlorite. These are commercially available concentrations, eliminating the need for cumbersome dilution systems and softened water.

The Model T70G4000 chlorine dioxide generator is an all-vacuum system, preventing the escape of chlorine dioxide gas to the atmosphere. The reagents are drawn into the generator by a vacuum, produced by an integral ejector. The chlorine dioxide gas produced by the generator is mixed with the ejector motive water and applied as a solution to the treatment process.

The Model T70G4000 chlorine dioxide generator is available for either manual or automatic control. Chlorine dioxide gas production can be manually controlled by manual rate valves located on the cabinet face or automatically controlled by a Chloromatic™ valve, which accepts a 4-20 mAdc input control signal from a flow transmitter or a residual controller.



DESIGN FEATURES

- ◆ **High Yield:** Generator has been designed to produce and consistently maintain a product yield greater than 95%.
- ◆ **All Liquid System:** 32% Hydrochloric acid and 25% sodium chlorite are the reagents used to generate chlorine dioxide. No chlorine gas is required.
- ◆ **All Vacuum System:** The reagents are drawn into the generator by a vacuum, produced by an integral ejector. The chlorine dioxide gas produced by the generator is mixed with the ejector motive water and applied as a solution.
- ◆ **Manual or Automatic Control Options**
- ◆ **Safe Operation:** An all-vacuum system prevents escape of gas to atmosphere and provides fail safe shut-down with loss of vacuum.
- ◆ **Minimum maintenance:** Corrosion-resistant materials; All periodic maintenance items are easily replaceable.



ENGINEERING SPECIFICATIONS

Capacities:

Standard chlorine dioxide generator units are available in the following maximum capacities: 4, 8, 16, 26, 53, 106, 212, 317, 423, 529 PPD (80, 150, 300, 500, 1000, 2000, 4000, 6000, 8000 10,000 g/h) of chlorine dioxide gas.

Flowmeter Rangeability:

10 to 1, flowmeter indication and control limits.

Control Options:

The generator can be controlled either manually or automatically. With a manually operated generator, reagent draw into the system is adjusted by manual rate valves located on each flowmeter located on the cabinet face. This, in conjunction with a differential pressure regulator, controls the rate of chlorine dioxide gas production. For an automatically controlled generator, reagent draw into the system is controlled by a Chloromatic™ valve, which is individually sized for each dosage capacity. The valve actuator is controlled by an electronic current/position converter that receives the control signal from either a process flow transmitter or a residual controller and adjusts the chlorine dioxide production accordingly.

Safety Features:

If a low vacuum condition exists, a valve will shut-off reagent flow to the generator. A vacuum regulating valve prevents both overpressure and excessive vacuum conditions. An optional flow vacuum switch is available for remote alarm indication. Each reagent flowmeter includes a detector with alarm, which detects the presence/absence of reagent with contacts available for alarm transmission.

Connections:

Ejector water inlet:	1" NPTF
Dilution water inlet:	1/2" NPTF
Chlorine dioxide solution:	1" NPTM
Reagents inlet:	1/2" NPTF
Drain:	1/2" NPTF

A connection kit is available for connecting the generator to the customer-supplied reagent tanks. The kit includes 39 feet (12 m) of hose and (7) 1/2" connectors.

Electrical Requirements:

120 VAC or 220 VAC, 50-60 Hz
50 VA Max.

Input/Output Signals:

- (1) 4-20 mAdc input for Chloromatic™ valve control
- Contact inputs for chlorine leak, reagent reservoir low level, dilution water low pressure and remote start/stop
- (1) 4-20 mAdc output, Chloromatic™ valve position
- Contact outputs for generator block, generator delayed block, internal alarm, hi/lo alarm, auto/manual status, watch dog, rated at 5A, 120 VAC.
- Optional serial link RS485, RS422, RS232

Temperature Limits:

41 to 86°F (5 to 30°C), optimum conditions are achieved at 68°F (20°C)

Reagents:

Commercially Available:

32% Hydrochloric Acid (Hydrofluoric Acid Free)
25% Sodium Chlorite

To produce 1 g of ClO₂ requires 4.3 ml of hydrochloric acid, 6 ml of sodium chlorite and 18.4 ml water.

Diluted reagents are recommended for low range generators (4, 8 and 16 PPD (80, 150 and 300 g/h). In this case, no reaction water is required. Dilution concentrations are: 8.5% hydrochloric acid (HF free) and 7.5% sodium chlorite.

In this case, to produce 1g of ClO₂ requires 23.2 ml of hydrochloric acid and 23.2 ml of sodium chlorite.

Dimensions:

24 x 60 x 25.6 inches (610 x 1524 x 650 mm)

Shipping Weight:

165 to 250 lbs (75 to 110 kg)

Standard Unit Features:

- Sight glass for chlorine dioxide solution, for visual verification of product quality
- Vacuum gauge, psi/kPa
- Alarm indication with manual reset

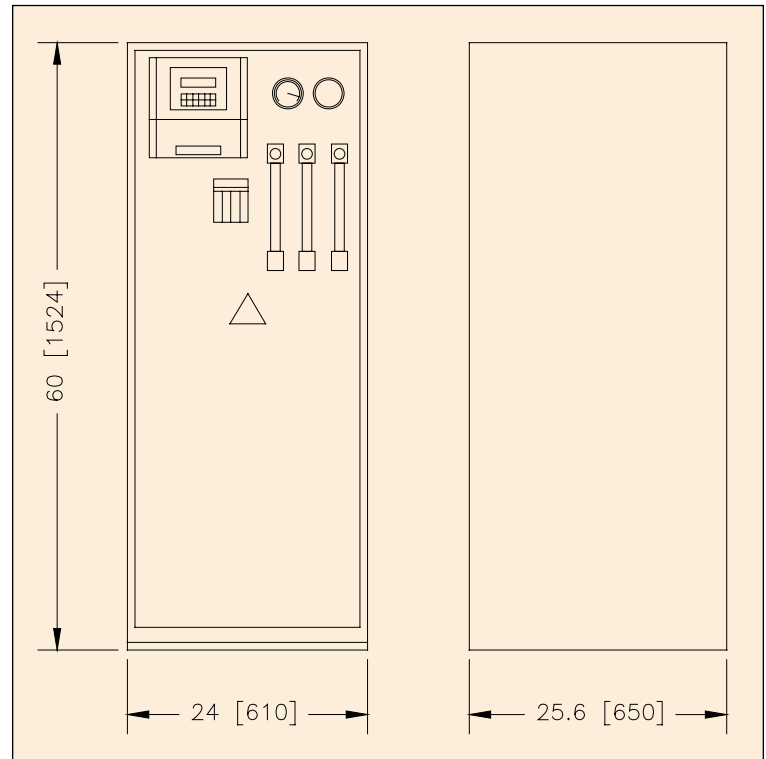

Figure 1 - Dimensions

MATERIALS OF CONSTRUCTION:

Cabinet: fiberglass reinforced polyester, white.

Hydraulic connections: teflon tubing

Reaction tower: rigid PVC, fiberglass reinforced

OPTIONAL ACCESSORIES AVAILABLE:

- Vacuum vent valve
- Vacuum switch
- Water line pressure reducing valve
- Reagent lines connector kit
- Reagent line filter
- Serial link (RS485, RS232 or RS422)
- Security control panel: Includes functions for power supply shut-down, ejector water supply shut-down, low vacuum alarm and retransmission signal, low reagent alarm and retransmission signals, chlorine dioxide gas presence in air alarm (for use with chlorine dioxide gas detector) and indication lights.
- Reagent transfer pump control panel for contractor supplied storage tanks and transfer pumps.

DESCRIPTION OF OPERATION

The hydrochloric acid and sodium chlorite reagents are drawn into the generator reaction chamber under a vacuum, produced by an integral ejector. For manual control systems, the reagent flow is controlled by manual rate control valves located on the flowmeters. For automatically controlled systems, reagent flow is controlled by a Chloromatic™ valve, which is individually sized for each dosage capacity. A regulated amount of water is also drawn into the reaction chamber to optimize the reaction.

The chlorine dioxide gas is drawn out of the reaction chamber under a vacuum produced by the integral ejector where it is mixed with the ejector motive water and applied as a solution. The solution is passed through a sight glass for visual verification of product quality. The entire system is completely under vacuum from reagent draw into the generator to the point of application. If a low vacuum condition exists, a valve will shut-off reagent flow to the generator. A low vacuum alarm contact is included. A vacuum regulating valve prevents both overpressure and excessive vacuum conditions.

An automatically controlled system utilizes a 4-20 mAdc input signal, one 4-20 mAdc output signal for Chloromatic™ valve position retransmission and contacts for automatic/manual operation, low vacuum alarm, two low reagent alarms.

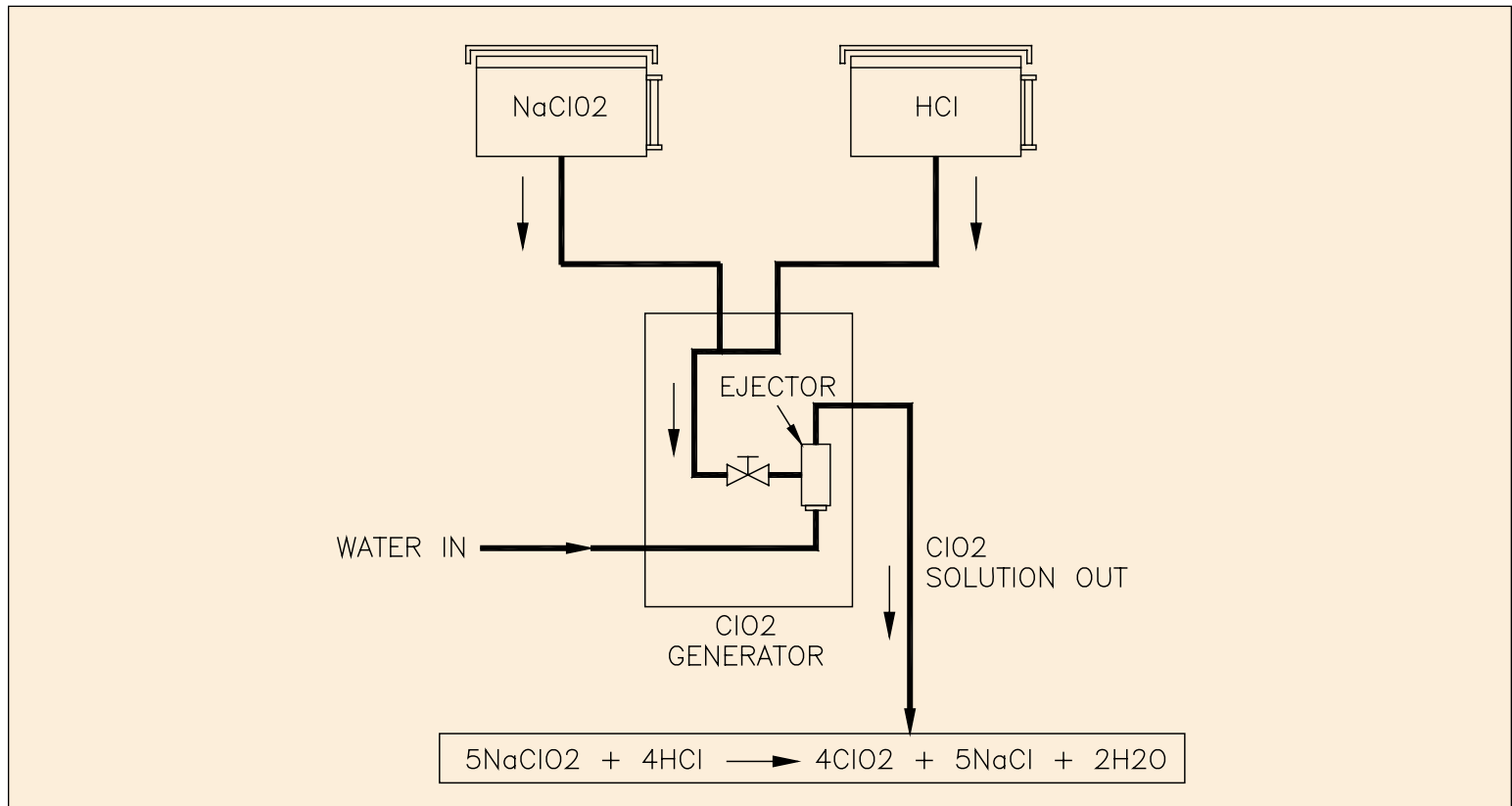

Figure 2 - Flow Diagram

EQUIPMENT DESCRIPTION

The chlorine dioxide generation system shall be an all-liquid, all-vacuum type with a capacity of _____ PPD (kg/h) of chlorine dioxide solution. The unit shall be designed to produce and consistently maintain a product yield greater than 95%.

The system shall be a two-chemical reagent type, utilizing hydrochloric acid and sodium chlorite, in commercially available concentrations, in the production of chlorine dioxide gas. No chlorine gas is required. The reagents are to be drawn into the generator by a vacuum, produced by an integral ejector.

The chlorine dioxide gas produced by the generator shall be mixed with the integral ejector motive water to form a solution that shall be fed to the point of application.

(Manual Systems) Reagent draw (flowrate) into the system shall be adjustable by manual rate valves located on each flowmeter. This, in conjunction with an integral differential pressure regulator, shall control the rate of chlorine dioxide gas production.

(Automatic Systems) The chlorine dioxide generating system shall be flow paced. Reagent draw into the system shall be controlled by a Chloromatic™ valve, which is to be individually sized for each dosage capacity. The Chloromatic™ valve actuator shall be controlled by an electronic current/position converter, that will receive a 4-20 mAdc signal from the process (flowmeter or control source) and adjust the rate of reagent draw accordingly in order to ultimately control the rate of chlorine dioxide production. One 4-20 mAdc output signal (for Chloromatic™ valve position), plus four contacts for remote indication of auto/manual mode and alarms shall be available.

The chlorine dioxide generator cabinet shall be constructed of fiberglass-reinforced polyester. The reaction chamber shall be constructed of rigid fiberglass-reinforced PVC.

Safety interlocks shall be provided to automatically shut down the system in the event of a loss of vacuum for any reason.

Severn Trent Services

3000 Advance Lane

Colmar, PA 18915

Telephone 215 997 4000

Fax 215 997 4062

marketing@severntrentservices.com

150.0010.2 02/06