

TETRA® SAF™ System

Submerged Aerated Filter for Wastewater Treatment

Severn Trent Services offers the TETRA SAF™, a simple process for the biological oxidation of ammonia-nitrogen (NH₃-N) and BOD for both municipal and industrial wastewaters. TETRA SAF offers exceptional performance, reliability, and operational and maintenance cost savings over competitive systems. TETRA SAF is an upflow, fixed-film biological reactor that uses coarse media requiring no backwashing. A robust and small footprint system, it can be used as either a secondary or tertiary treatment. When combined with primary and final settlement, TETRA SAF offers a complete high performance treatment process. TETRA SAF is a simpler alternative to more complex treatments such as activated sludge and Biological Aerated Filters (BAF), which require more extensive operator input and process monitoring and control. The design encourages the growth of a robust biomass capable of consistently producing high quality effluents, even during large variations in hydraulic and biological loadings.



TETRA SAF Operational Description

TETRA SAF is an upflow, fixed-film biological reactor that uses a coarse 25-40 mm nominal diameter media. The media is an excellent support medium for aerobic bacteria. Media depths up to 20 feet are used. Fine-screened wastewater and process air are fed into the bottom of the reactor. Wastewater is transferred to an influent splitter box using a low head pump. The box sets above the reactor and connected to a specially designed influent pipe system that feeds the bottom of the reactor.

Ammonia and BOD can be removed in the same step or in separate reactors depending upon the wastewater treatment requirements. Biological organisms grow on the media surface. The biological reaction occurs in an aerobic environment. As the wastewater passes over the media, BOD and NH₃-N are converted into biological solids. These solids are not captured but continuously released from the media bed. The solids are either removed via clarification or filtration depending upon system requirements. Since the influent solids and generated solids are always being released with the treated wastewater, no backwashing is required. A maintenance influent pipe flush is conducted periodically to flush any settled solids or debris from the influent piping.

Performance

Effluent qualities of 5:1 BOD to NH₃-N (mg/l) can easily be achieved. Effluent NH₃-N of less than 0.5 mg/l has been demonstrated. Typical loading rates of 80 lbs/1000 ft³/day BOD and 30 lbs/1000 ft³/day ammonia can be achieved. Table 1 lists some TETRA SAF installations.

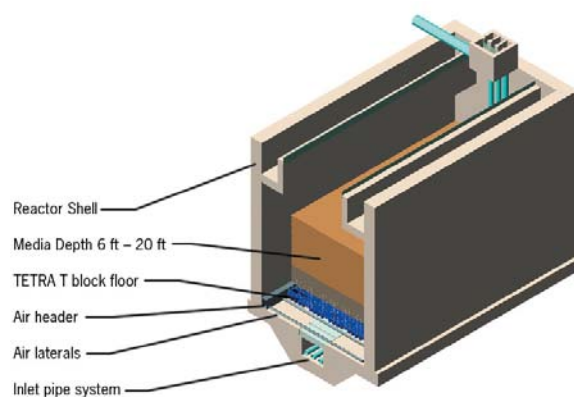

Treatment Schemes-Applications

TETRA SAF™ is used to treat biologically degradable effluents from a wide variety of sources:

- It is used in combination with the TETRA Denite® denitrification filter to meet superior total nitrogen limits (as shown in Figure 1).
- It is used in conjunction with existing biological operations downstream of the secondary clarifiers for additional ammonia and/or BOD reduction.
- It is used for primary treatment of BOD followed by clarification and SAF for ammonia reduction.

Proven Operational and Maintenance Advantages

TETRA SAF has a number of advantages over the alternate technologies such as BAF, activated sludge, oxidation ditches, and rotating biological contactors.

- Guaranteed system performance
- Produces high effluent qualities; tolerates variations in biological and solids loadings
- Eliminates the high headloss conditions allowing the use of deeper media beds
- Eliminates the plugging potential typically associated with BAF
- Eliminates air and water distribution problems
- A true low-maintenance system: No backwashes are required, so no automatic valves, backwash pumps, backwash blowers, clearwell, mudwell are required. Process air blowers and low head feed pumps constitute the only major power requirement
- Minimal process monitoring is required releasing valuable operator time
- Utilizes a durable media with a long proven performance life in excess of 20 years
- The reactor does not contain moving or serviceable parts minimizing system down time and operational expenditures due to breakages and the replacement of worn components
- Its small footprint makes it the ideal choice for applications where space is limited or where future upgrades will be needed

TETRA SAF System Components and Specifications

- **Reactor Vessel:** concrete or steel, round or rectangular. Height dependent upon media depth
- **Reactor Bottom:** nozzleless design; stainless steel air headers and pipe laterals; plastic jacketed 5000 psi concrete T Block underdrains. Bottom design currently used in TETRA DeepBed filters, TETRA Denite filters and TETRA BAF plants worldwide
- **Reactor Media:** 25–40 mm effective size; 6–20 foot depths; strong, durable, long lifetime that cannot collapse or be lost in flotation
- **Process Air:** distributed across the entire area of the filter bottom supplied by a positive displacement blower
- **Backwash Requirements:** none; periodic manual influent pipe flush
- **Reactor Valves:** automatic not required; manual influent, effluent, and flush/drain
- **Reactor Operations:** no automatic sequencing required
- **Instrumentation:** minimal if any required; no PLC required

Location	Year	Flow (MGD)	Design Objective
Halifax-UK	1999	32.6	Ammonia
Danesmoor-UK	1998	0.95	Ammonia
Raunds-UK	2000	1.85	Ammonia
Faulderhouse-UK	1998	0.85	BOD/Ammonia
HengJi-China	2002	5.28	BOD/Ammonia

